

## Inline Inductor MI-25, 25/40, 40, 50, and 65

### Description

The stationary inline inductor injects foam liquid into a water stream. The inductor can handle high back-pressures, extending the distance from the injection point to the foam applicator.

### Application Description

An inline inductor is used in fixed installations to inject low, medium, and high-expansion foam concentrates into water flow lines for deluge and fire monitor installations.

### Product Features

- Corrosion resistant with brass body construction
- Factory calibrated to any flow and pressure within the range
- Integrated suction check valve
- MI series ranges from 70 Lpm at 5 bar (18 gpm at 73 psi) to 1,450 Lpm at 16 bar (383 gpm at 232 psi) inlet pressure
- Suction height up to 3.5 m (11.5 ft)
- Foam induction up to 6%.
- Installation in horizontal or vertical plane
- Hot-dipped galvanized steel flanges

### Installation

- Water inlet/outlet: to fit DIN PN16 or ANSI 150 lb or screw threaded BSP
- A minimum of five nominal pipe diameters of straight pipe upstream and downstream of the inline inductor shall be used.
- Foam inlet check valve: screw threaded BSP Female

### Optional Components

- Optional bronze flanges
- Foam concentrate suction hose
- Inductors available in alternative materials. Contact Johnson Controls for further details.

### Listings and Approvals

- Russian Maritime Register of Shipping (RMRS)
- Det Norske Veritas DNV (MI-25, 25/40, 40 for use with MLR-40/SA systems only)

### Ordering Information

When ordering, specify the following information:

- Part number
- Flow (Lpm)
- Pressure (bar)
- Induction rate (%)



E000497

### Capacity Range for Inline Inductors

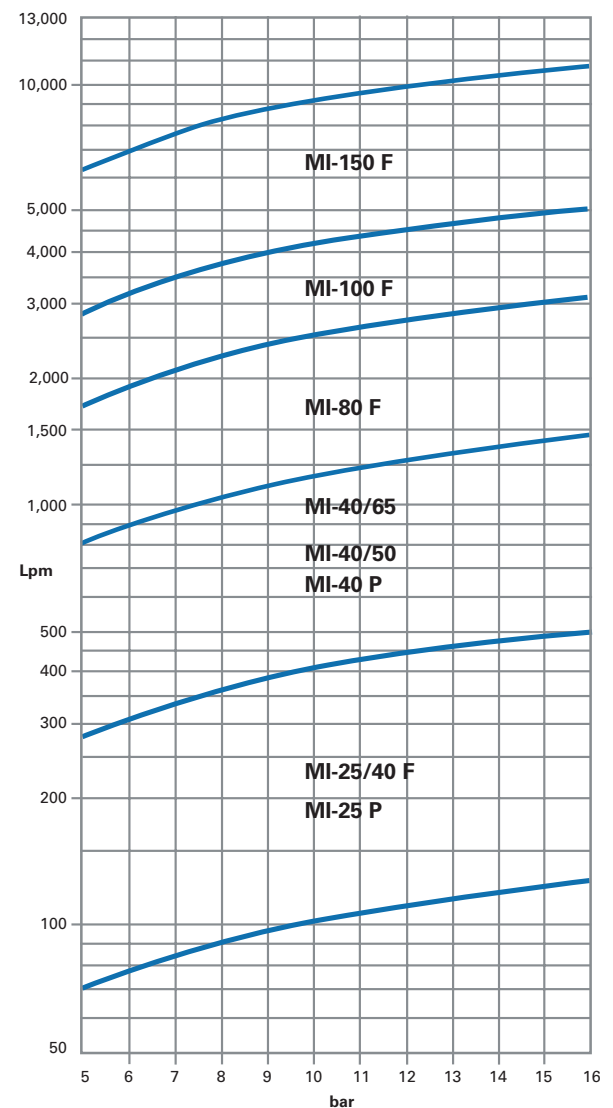

**Note:** 6% induction is not available for all flows. See the Performance Data table.

**Note:** The converted values in this document are provided for dimensional reference only and do not reflect an actual measurement.

SKUM, and the product names listed in this material, are marks and/or registered marks. Unauthorized use is strictly prohibited.

## Ordering Information (Continued)

Part No.	Description	Dimension - mm (in.)		
		A	B	C
121102505	MI-25 F	159 (6.3)	97 (3.8)	30 (1.2)
121102422	MI-25 F 3% or 6%	163 (6.4)	155 (6.1)	27 (1.1)
121102519	MI-25/40 F DIN	220 (8.7)	100 (3.9)	58 (2.3)
121102630	MI-25/40 F ANSI	220 (8.7)	100 (3.9)	58 (2.3)
121102533	MI-25/50 F DIN	225 (8.9)	100 (3.9)	60 (2.4)
121105637	MI-25/50 F ANSI	225 (8.9)	100 (3.9)	60 (2.4)
121102512	MI-25/F 2 in. BSP male	220 (8.7)	90 (3.5)	56 (2.2)
121102402	MI-25/P, c/w suction hose and tube, > in., 1.5 m	163 (6.4)	-	-
121304100	MI-40 F BSP	218 (8.6)	123 (4.8)	43 (1.7)
121304103	MI-40 F DIN	300 (11.8)	123 (4.8)	84 (3.3)
121304105	MI-40 F DIN 3% to 6%	300 (11.8)	123 (4.8)	84 (3.3)
121304201	MI-40 F ANSI	300 (11.8)	123 (4.8)	84 (3.3)
121304204	MI-40 F ANSI 3% to 6%	300 (11.8)	123 (4.8)	84 (3.3)
121304802	MI-40 P FC/T 1 in. 1.5 m	218 (8.6)	123 (4.8)	43 (1.7)
121304107	MI-50 F DIN	300 (11.8)	123 (4.8)	90 (3.5)

Part No.	Description	Dimension - mm (in.)		
		A	B	C
121304110	MI-50 F DIN 3% to 6%	310 (12.2)	205 (8.1)	90 (3.5)
121304205	MI-50 F ANSI	310 (12.2)	123 (4.8)	90 (3.5)
121304207	MI-50 F ANSI 3% to 6%	310 (12.2)	205 (8.1)	90 (3.5)
121304114	MI-65 F DIN	330 (13.0)	123 (4.8)	100 (3.9)
121304128	MI-65 F DIN 3% to 6%	310 (12.2)	205 (8.1)	100 (3.9)
121304212	MI-65 F ANSI	330 (13.0)	123 (4.8)	100 (3.9)
121304226	MI-65 F ANSI 3% to 6%	310 (12.2)	205 (8.1)	100 (3.9)
121802305	MI-25 suction hose FC/V foam valve > in. 1.5 m	-	-	-
121802181	MI-25 suction hose with tube FC/T 1/2 in. 1.5 m	-	-	-
121804059	MI-40 suction hose FC 1 in. 1.5 m	-	-	-
121804024	MI-40 suction hose with tube FC/T 1 in. 1.5 m	-	-	-
121804307	MI-40-65 suction hose FC/V foam valve 1 in. 1.5 m	-	-	-

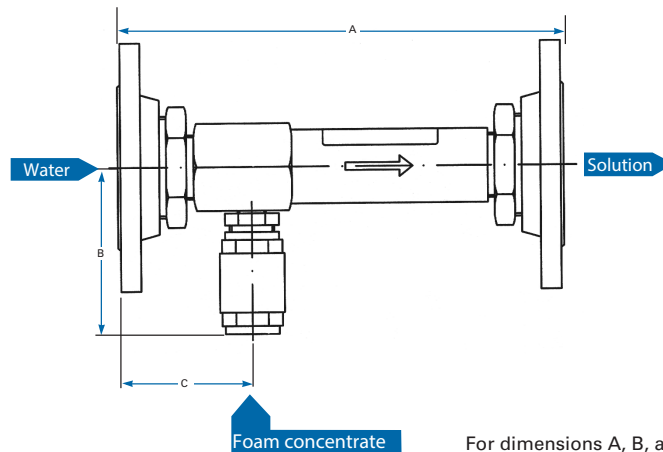

For dimensions A, B, and C, see the tables in Ordering Information

## Performance Data

	MI-25 and MI-25/40	MI-40, MI-50, and MI-65
<b>Water capacity at 16 bar (232 psi)</b>	Maximum 500 Lpm (132 gpm)	Maximum 1,450 Lpm (383 gpm)
<b>Total capacity for 6% induction</b>	Maximum 250 Lpm (66 gpm)	Maximum 725 Lpm (192 gpm) for MI-50
<b>Working pressure</b>	Maximum 16 bar (232 psi)	Maximum 16 bar (232 psi)
<b>Proportioning</b>	Maximum 6%	Maximum 6%
<b>Pressure drop</b>	Approximately 35% of inlet pressure	Approximately 35% of inlet pressure

	MI-25	MI-25/40	MI-40	MI-50	MI-65
<b>Connection: Water</b>	Male 1 in. BSP	40 DIN PN 16 or 1 1/2 in. ANSI 150 lb	Female 1 1/2 in	50 DIN PN 16 or 2 in. ANSI 150 lb	65 DIN PN 16 or 2 1/2 in. ANSI 150 lb
<b>Connection: Foam</b>	Female 1/2 in. BSP	Female 1/2 in. BSP	Female 1 in. BSP	Female 1 in. BSP	Female 1 in. BSP
<b>Weight</b>	2.6 kg (5.7 lb)	7.0 kg (15.4 lb)	5.5 kg (12.1 kg)	7.0 kg (15.4 lb)	13.0 kg (28.6 lb)
<b>Material: Body</b>	Brass	Brass	Brass	Brass	Brass
<b>Material: Flange</b>	Galvanized steel	Galvanized steel	Galvanized steel	Galvanized steel	Galvanized steel
<b>Included</b>	Foam concentrate check valve	Foam concentrate check valve	Foam concentrate check valve	Foam concentrate check valve	Foam concentrate check valve
<b>Optional</b>	Foam concentrate suction hose	Foam concentrate suction hose	Foam concentrate suction hose	Foam concentrate suction hose	Foam concentrate suction hose

1 bar = 0.1 MPa = 14.5 psi