

## FJM-MAN Manual Fog/Jet Monitor

### Description

- FJM-MAN monitors are manually operated fog/jet, water, and foam monitors with exceptional flow characteristics that optimize the throw range.
- FJM-MAN manual fog/jet monitors ensure an exceptional delivery of water or foam as a jet or as a spray pattern.
- The FJM-MAN manual fog/jet monitor range is available for alternate mounting positions.
- SKUM supply FJM and the FJM-S options. The FJM-S monitor has an inbuilt foam concentrate inductor to eliminate the need for a separate proportioning system for certain agents.

### Application

- FJM fog/jet monitors are designed for easy operation and reliability.
- The lighter construction materials of the monitor ensure an overall light weight.
- FJM monitors have a wide operating range and are site adjustable to any demands of the local environment while maintaining the highest performance levels.

**Note:** When running any of the FJM-S range of monitors, adjust to the nominal capacity for accurate proportioning.

### Features

- Wide capacity range
- Adjustable flow
- Compact and balanced design
- Low weight
- Low friction bearings for easy manoeuvres
- Long throw length
- Adjustable stream pattern
- Stainless steel and bronze corrosion-resistant construction

### Connections

- Foam/water inlet is flanged according to DIN PN 16, JIS 10K, or ANSI 150 lb

### Optional components

- Built-in inductor on all models (S version)
- Gear operation for FJM-150 models or standard for FJM-200 models
- Suction hose and valve



### Listings and approvals

- Det Norske Veritas (DNV)
- Bureau Veritas
- Russian Maritime Register of Shipping (RMRS)
- CNBOP (Poland) available upon request

### Ordering information

When ordering, specify the following information:

- Part number (see Table 1)
- Monitor type
- Flange type
- Capacity: flow and pressure
- Foam induction (S version)

## Ordering information (Continued)

**Table 1: Part details**

Part No.	Description
161008407	FJM-80 DIN/ANSI
161008319	FJM-80 JIS
161008340	FJM-80 S DIN/ANSI, excluding suction hose
161008537	FJM-80 S JIS, excluding suction hose
160208305	FJM-80 ANSI
161008423	FJM-80 S ANSI, excluding suction hose
161008618	FJM-80 suction hose 1 1/4 in. 3 m
161010403	FJM-100 DIN/ANSI
161010216	FJM-100 JIS
161010315	FJM-100 S DIN/ANSI, excluding suction hose
161010417	FJM-100 ANSI
161010329	FJM-100 S ANSI, excluding suction hose
16101606	FJM-100 suction hose 2 in. 3 m
161015304	FJM-150 DIN/ANSI/JIS
161015405	FJM-150 S DIN/ANSI, excluding suction hose
161315317	FJM-150 G DIN/ANSI/JIS
161315338	FJM-150 S G DIN/ANSI/JIS, excluding suction hose
161015608	FJM-150 suction hose 2 in. 3 m
161320127	FJM-200 G DIN
161320229	FJM-200 G ANSI
162020260	FJM-200 S G ANSI, excluding suction hose
161320236	FJM-200 G JIS
162020267	FJM-200 S G JIS, excluding suction hose
161020618	FJM-200 suction hose 2.5 in. 3 m

## Capacity ranges

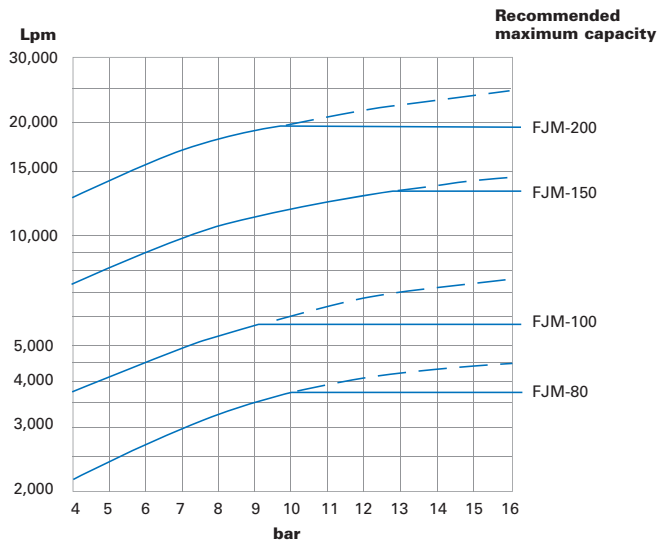

## FJM-80

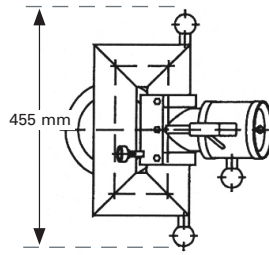
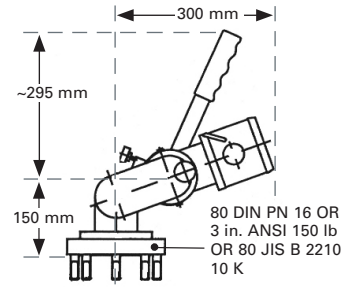

## FJM-80 S

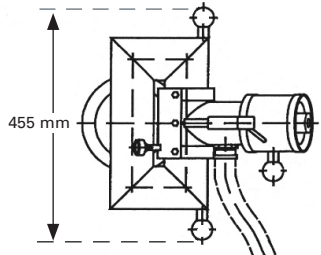
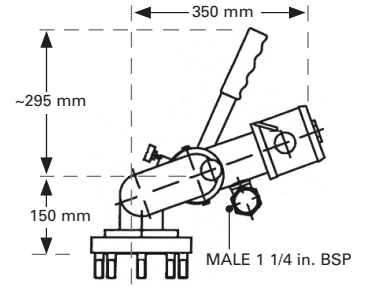

## FJM-80 monitor range of jet

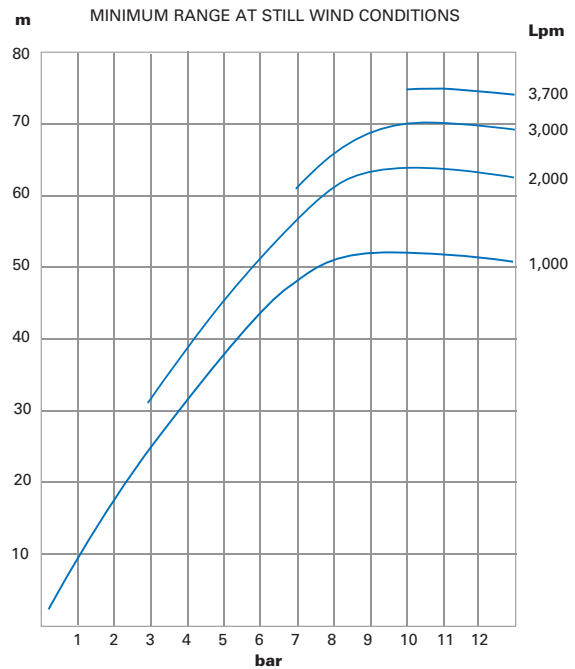

**Notes:** 1. Reaction force (N) = 0.233 x Q (Lpm) x  $\sqrt{p}$  (bar)

2. Deduct 10% for self-induction nozzles.

3. Achieving the values listed in the range of jet graph depends on the monitor's elevation angle. For further details, see the length-height relationship graph.

## FJM-100

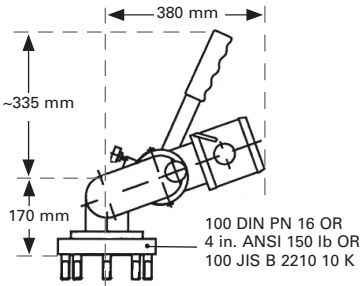

## FJM-100 S

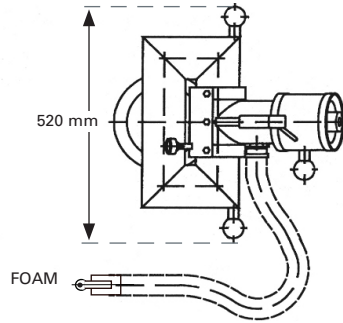
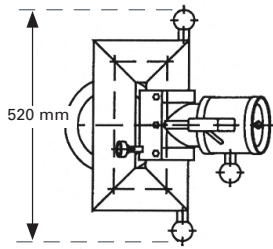
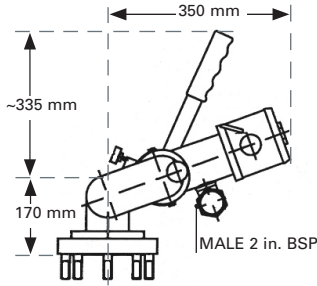

## FJM-150

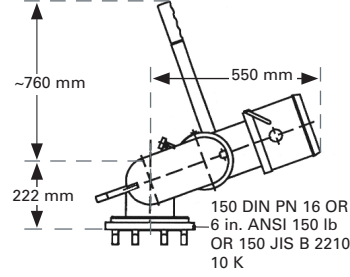

## FJM-150 S

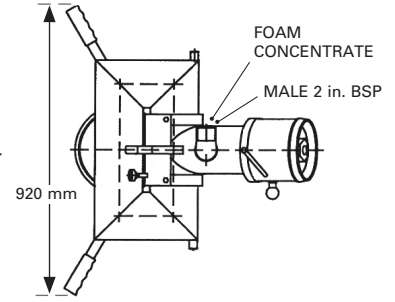
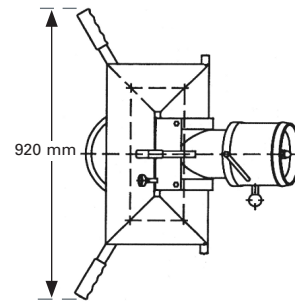
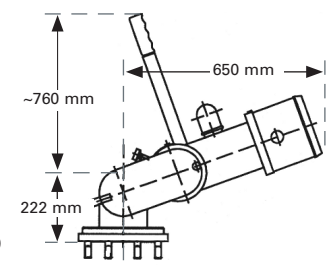

## FJM-100 monitor range of jet

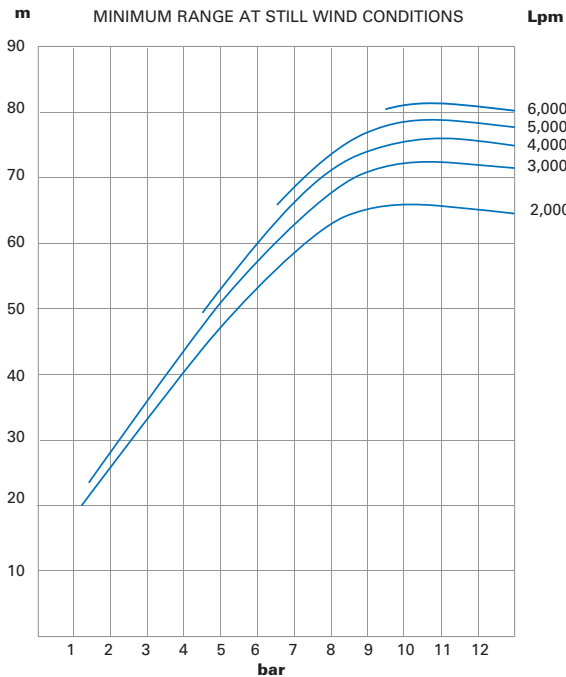

- Notes:**
1. Reaction force (N) =  $0.233 \times Q \text{ (Lpm)} \times \sqrt{p \text{ (bar)}}$
  2. Deduct 10% for self-induction nozzles.
  3. Achieving the values listed in the range of jet graph depends on the monitor's elevation angle. For further details, see the length-height relationship graph.

## FJM-150 monitor range of jet

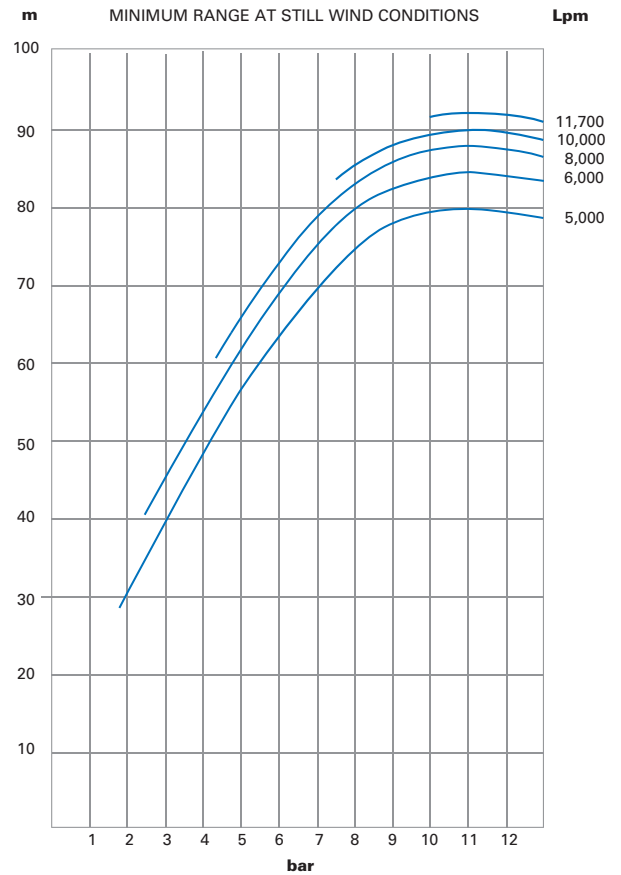

- Notes:**
1. Reaction force (N) =  $0.233 \times Q \text{ (Lpm)} \times \sqrt{p \text{ (bar)}}$
  2. Deduct 10% for self-induction nozzles.
  3. Achieving the values listed in the range of jet graph depends on the monitor's elevation angle. For further details, see the length-height relationship graph.

## FJM-150 G

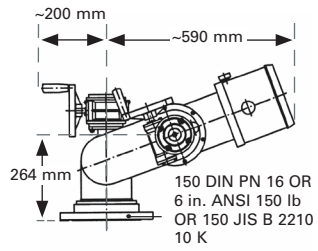

## FJM-150 SG

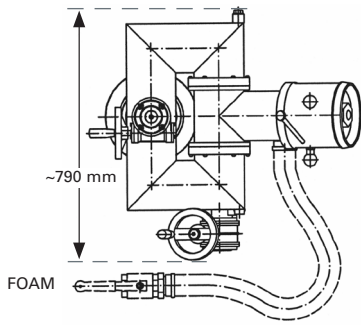
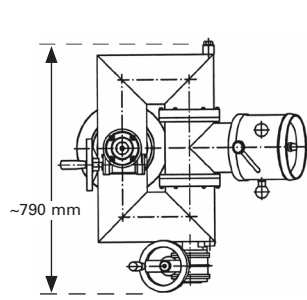
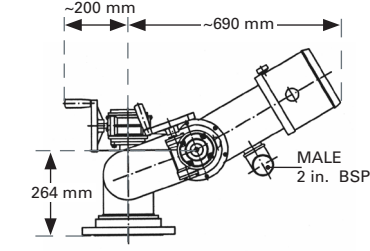

## FJM-200 G

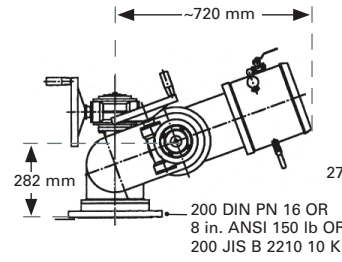

## FJM-200 SG

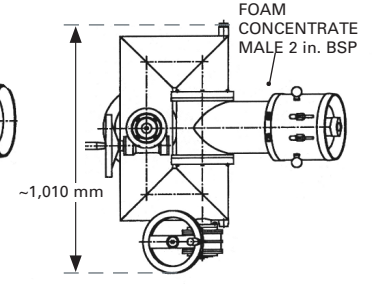
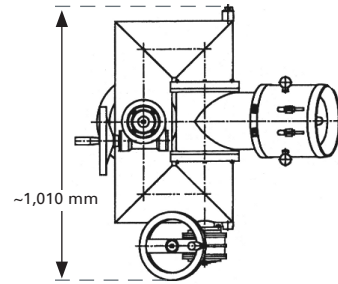
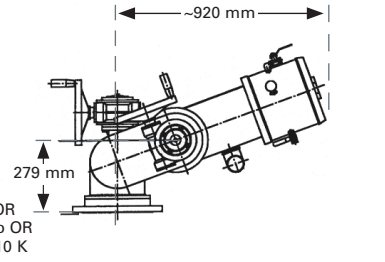

## FJM-200 monitor range of jet

MINIMUM RANGE AT STILL WIND CONDITIONS

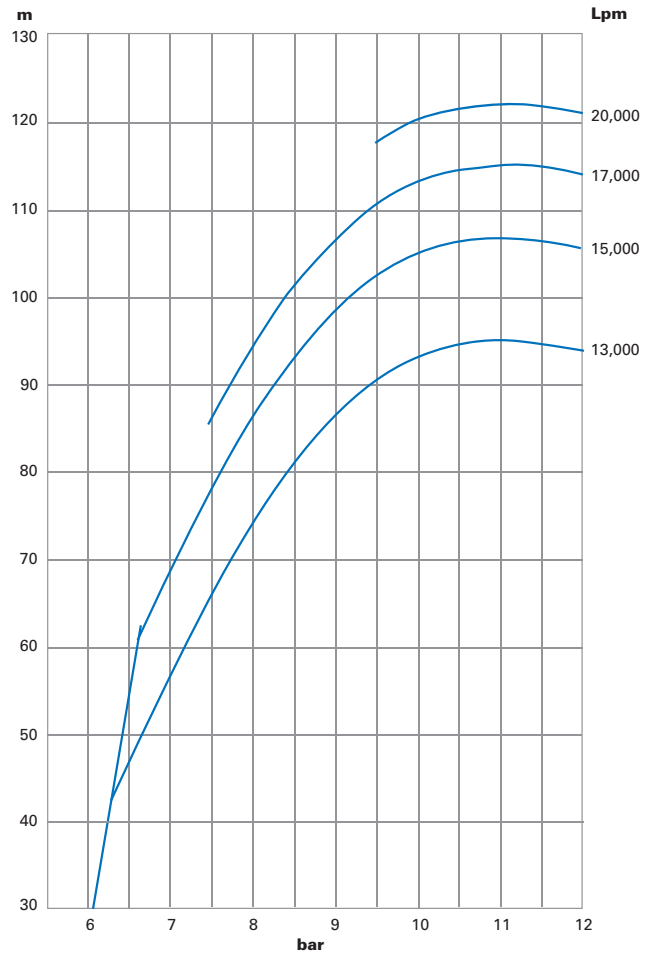

**Notes:** 1. Reaction force (N) = 0.233 x Q (Lpm) x √p (bar)

2. Deduct 10% for self-induction nozzles.

3. Achieving the values listed in the range of jet graph depends on the monitor's elevation angle. For further details, see the length-height relationship graph.

## Length and height relationship

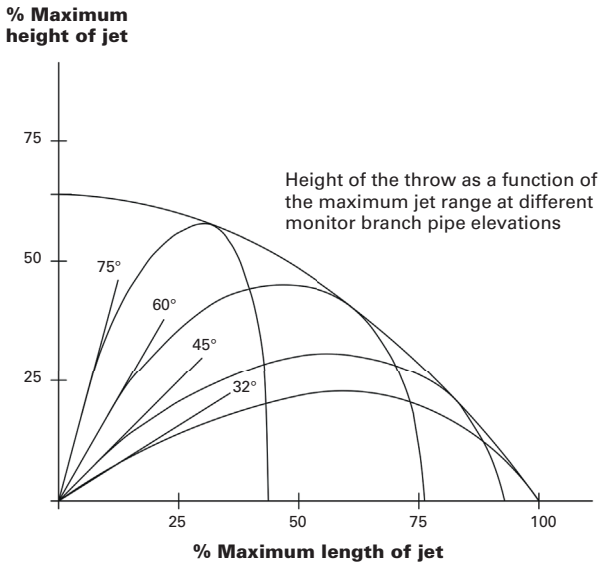

**Note:** Reaction force (N) =  $0.233 \times Q \text{ (Lpm)} \times \sqrt{p \text{ (bar)}}$

## Average fog pattern in still air

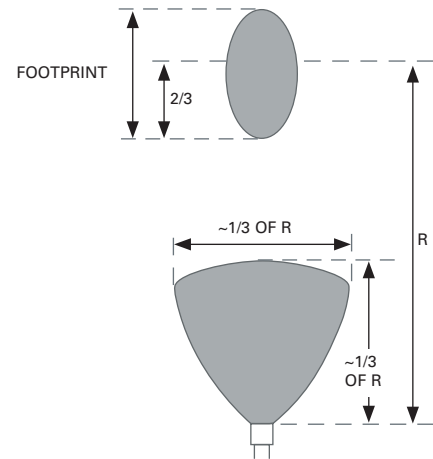

**Note:** R = Jet range

## Performance data

**Table 2: Performance data**

FJM series standard	FJM-80	FJM-100	FJM-150	FJM-200
<b>Water capacity</b>	Maximum 3,700 Lpm Minimum 500 Lpm	Maximum 6,000 Lpm Minimum 1,000 Lpm	Maximum 11,700 Lpm Minimum 3,000 Lpm	Maximum 20,000 Lpm Minimum 8,000 Lpm
<b>Design pressure</b>	4 bar to 16 bar optimum 10 bar to 12 bar	4 bar to 16 bar optimum 10 bar to 12 bar	4 bar to 16 bar optimum 10 bar to 12 bar	4 bar to 13 bar optimum 10 bar to 12 bar
<b>Rotation</b>	360°	360°	360°	360°
<b>Elevation</b>	-60° / +90°	-60° / +90°	-60° / +70°	-60° / +70°
<b>Connection flange</b>	Stud bolt	Stud bolt	Open hole	Open hole
<b>Weight</b>	14 kg	22 kg	57 kg	90 kg
FJM series built-in inductor	FJM-80	FJM-100	FJM-150	FJM-200
<b>Water capacity</b>	Maximum 3,700 Lpm Minimum 500 Lpm	Maximum 6,000 Lpm Minimum 1,000 Lpm	Maximum 11,700 Lpm Minimum 3,000 Lpm	Maximum 20,000 Lpm Minimum 8,000 Lpm
<b>Design pressure</b>	4 bar to 16 bar optimum 10 bar to 12 bar	4 bar to 16 bar optimum 10 bar to 12 bar	4 bar to 16 bar optimum 10 bar to 12 bar	4 bar to 13 bar optimum 10 bar to 12 bar
<b>Foam capacity</b>	170 Lpm	320 Lpm	600 Lpm	600 Lpm
<b>Elevation</b>	-45° / +90°	-45° / +90°	-45° / +70°	-45° / +70°
<b>Suction connection</b>	1 1/4 in. BSP male	2 in. BSP male	2 in. BSP male	2 in. BSP male
<b>Weight</b>	15 kg	24 kg	60 kg	93 kg

SKUM, and the product names listed in this material are marks and/or registered marks. Unauthorized use is strictly prohibited.