

Model MTB-ASME Horizontal Bladder Tanks

Features

- UL Listed and FM Approved for use with various proportioners and foam concentrates
- 175 psi (12.1 bar) maximum allowable working pressure (design pressure)
- Nominal capacities up to 11,356 liters with larger tanks available on special request
- Tanks up to 3,028 liters meet the requirements for Seismic Zone 4 earthquake resistant design
- Available with brass or 316 stainless steel trim piping and valves
- Options for grooved, NPT, and flanged connections
- Choice of Standard or Corrosion-Resistant Epoxy exterior paint, available in a variety of colors
- Optional sight gauge and thermal pressure relief valves available

Application

The SKUM MTB-ASME Horizontal Bladder Tank is one component of a balanced pressure proportioning system. SKUM bladder tanks require only a pressurized water supply for operation. No other external power is required. They can be used with one or more SKUM proportioners and any suitable discharge device to create a complete the foam system. SKUM bladder tanks can be used with most SKUM foam concentrates.

SKUM bladder tanks have numerous applications including aircraft hangars, foam-water sprinkler systems, truck loading racks, and helipads.

Description

The SKUM bladder tank is a steel pressure vessel, which stores a foam concentrate within an elastomeric bladder. The concentrate is discharged from the tank by incoming water applying pressure to the bladder. This applied energy is transferred to the concentrate, supplying pressurized concentrate to the proportioner (Proportioners are separate items described on a separate data sheet).

Trim Piping and Connections

SKUM bladder tanks are available in horizontal models up to 3,000 gal (11,356 L). All models feature top discharge foam concentrate connections and the option to pipe using either grooved or NPT threaded connections. Adapters for flanged connections are available separately. Trim piping is available in brass or stainless steel. All valves are clearly identified by permanently attached nameplates and can be secured in position with included ring pins and tamper seals.



001154b

Protective Coatings

All SKUM bladder tanks feature a high-build epoxy internal coating. Exterior paint is available in two grades: Standard and Corrosion-Resistant Epoxy (Epoxy CR). Paint systems used on SKUM bladder tanks have been subjected to and passed salt spray corrosion testing per ASTM B117-90. Standard paint has been tested to a minimum of 240 hours in accordance with UL 162, UL 139, and FM 5130. Epoxy CR paint has been tested to a minimum of 3,000 hours and is suitable for marine and offshore use.

Support and Mounting

Horizontal tanks are supported by two saddles with slotted holes for mounting. Refer to dimensional drawings for mounting hole spacing.

Horizontal Tanks

Diameter	Nominal Capacity	Mounting Slot Size
24 in. to 42 in. (610 mm to 1,067 mm)	100 gal to 400 gal (379 L to 1,514 L)	5/8 in. x 1 1/4 in. (16 mm x 32 mm)
48 in. (1,219 mm)	500 gal to 800 gal (1,893 L to 3,028 L)	7/8 in. x 1 1/4 in. (22 mm x 32 mm)
60 in. to 72 in. (1,524 mm to 1,829 mm)	900 gal to 3,000 gal (3,407 L to 11,356 L)	1 in x 1 1/4 in. (25 mm x 32 mm)

Each tank is fitted with two lifting lugs designed to lift the empty weight of the tank with a minimum safety factor of 2 when utilizing appropriate slings rigged at a lifting angle of not less than 30 degrees from horizontal. All lifting lugs have a minimum clear hole size of 2 in. (50 mm).

Internal Components

SKUM bladder tanks contain an elastomeric bladder that has been approved for use by Underwriter's Laboratory and FM Approvals for use with SKUM foam concentrates. All SKUM bladder tanks utilize a center tube(s) to facilitate agent discharge. Center tubes are constructed of materials compatible with SKUM foam concentrates. Horizontal tanks utilize two center tubes, one oriented horizontally and one oriented vertically, connected by a cross fitting.

Description (Continued)

Sight Gauge

A sight gauge is available as an optional accessory for SKUM bladder tanks for estimation of the fill level in the tank. The sight gauge is equipped with a clear 1 in. PVC tube. The sight gauge is shipped as a loose item and must be assembled on the tank during installation.

Thermal Relief Valve

A thermal relief valve is available as an option for SKUM bladder tanks. A thermal relief valve should be used when the bladder tank will be stored in an isolated/hydraulically locked condition in order to relieve pressure due to thermal expansion. This valve is factory set to 175 psi (12.1 bar) and it is recommended that the design pressure of the system be maintained at least 5 psi (0.34 bar) or 10% below the set pressure of the valve to avoid seat leakage and early valve maintenance. This valve is NOT a substitute for a properly sized ASME pressure relief valve to protect the entire system from overpressure.

ASME Information

The SKUM MTB-ASME Horizontal Bladder Tank is designed and constructed in accordance with the latest revisions to ASME Code Section VIII, Division 1 for unfired pressure vessels with a maximum allowable working pressure (MAWP) of 175 psi (12.1 bar) and tested to the pressure specified by the applicable codes and standards. Tanks designed to ASME code are tested to at least 230 psi (15.9 bar). CE marked tanks are tested to at least 255 psi (17.6 bar). All SKUM bladder tanks are constructed of steel complying with ASME specifications. Tank heads are 2:1 elliptical unless otherwise specified.

All SKUM bladder tanks include a permanently affixed stainless steel ASME data plate. At a minimum, the data plate includes the following information: year of manufacture, maximum allowable working pressure (MAWP), nominal volume, part number, National Board number, minimum material thickness, minimum design metal temperature (MDMT), and type of head used.

Approvals and Certifications

SKUM bladder tanks are UL Listed and FM Approved for use with various SKUM foam concentrates and proportioners. The UL mark and FM Approval diamond are applied at the factory along with a label identifying the SKUM foam concentrate for use in the tank.

Every tank bears a permanently affixed ASME data plate showing the National Board number which identifies the tank as compliant with ASME code Section VIII, Division 1 for unfired pressure vessels.

SKUM bladder tanks 200 gal (757 L) and larger are CE marked in conformance with the European Pressure Equipment Directive, 2014/68/EU. Under European Pressure Equipment Directive 2014/68/EU, tanks smaller than 200 gal (757 L) are acceptable based on sound engineering practices of ASME code and cannot be CE marked.

SKUM bladder tanks up to 800 gal (3,028 L) meet the minimum requirements for Seismic Zone 4 Earthquake Resistant Design as calculated according to the 1997 Uniform Building Code.

Operation and Maintenance

Refer to the SKUM Horizontal and Vertical Bladder Tank Operation and Maintenance Manual for detailed procedures on installation, operation, inspection, and maintenance. A printed copy of this manual is included with every tank.

Valve Position Information

Valve* No.	Valve Description	Normal Valve Position	
	Description	Manual System	Automatic System
1.	Manual Foam Concentrate Shutoff (Not shown)	N.C.**	N.O.***
2.	Water Supply Shut-Off (Not Shown)	N.C.	N.O.
3.	Sight Gauge Shut-Off (Not Shown)	N.C.	N.C.
4.	Tank Shell Vent Valve	N.C.	N.C.
5.	Bladder Vent Valve	N.C.	N.C.
6.	Tank Shell Drain Valve	N.C.	N.C.
7.	Bladder Drain/Fill Valve	N.C.	N.C.
8.	Automatic Foam Concentrate Isolation (Not Shown)	–	N.C.
9.	Isolation Valve	N.C.	N.C.

*Reference dimensional drawings for valve location

**N.C. – Normally Closed

***N.O. – Normally Open

In this arrangement, valves listed as “Not Shown” are either supplied as loose items or supplied by others.

Dimension Information (Reference Dimensional Drawings)

Part No.	Nominal Capacity		Diameter		Tank Weight (Empty)		Water Inlet –	Concentrate Outlet –	Tank Shell	Bladder Vent/	Bladder Drain/	Tank Shell	A		B		C	
	gal	(L)	in.	(mm)	lb.	(kg)	NPT or Grooved	NPT or Grooved	Vent – NPT	Fill – NPT	Fill – NPT	Drain – NPT	in.	(mm)	in.	(mm)	in.	(mm)
444124	100	(379)	24	(610)	598	(271)	2	2	1	1	1	1	53	(1,346)	45 3/4	(1,162)	74 1/2	(1,892)
444125	150	(568)	30	(762)	824	(374)	2	2	1	1	1	1 1/2	58 1/2	(1,486)	51 3/4	(1,314)	74	(1,880)
444126	200	(757)	30	(762)	929	(421)	2	2	1	1	1	1 1/2	58 1/2	(1,486)	51 3/4	(1,314)	93 1/2	(2,375)
444127	300	(1,136)	42	(1,067)	1,429	(648)	2	2	1	1	1	1 1/2	70 1/2	(1,791)	63 3/4	(1,619)	76 1/2	(1,943)
444128	400	(1,514)	42	(1,067)	1,668	(757)	2	2	1	1	1	1 1/2	70 1/2	(1,791)	63 3/4	(1,619)	96 1/2	(2,451)
444129	500	(1,893)	48	(1,219)	2,053	(931)	3	3	1	1	1	1 1/2	78	(1,981)	71	(1,803)	94	(2,388)
444130	600	(2,271)	48	(1,219)	2,261	(1,026)	3	3	1	1	1	1 1/2	78	(1,981)	71	(1,803)	109	(2,769)
444131	700	(2,650)	48	(1,219)	2,467	(1,119)	3	3	1	1	1	1 1/2	78	(1,981)	71	(1,803)	123 1/2	(3,137)
444132	800	(3,028)	48	(1,219)	2,702	(1,226)	3	3	1	1	1	1 1/2	78	(1,981)	71	(1,803)	140	(3,556)
444133	900	(3,407)	60	(1,524)	3,075	(1,395)	3	3	1	1	1	1 1/2	90	(2,286)	82 1/4	(2,089)	108	(2,743)
444134	1,000	(3,785)	60	(1,524)	3,275	(1,486)	3	3	1	1	1	1 1/2	90	(2,286)	82 1/4	(2,089)	118	(2,997)
444135	1,200	(4,542)	60	(1,524)	3,571	(1,620)	3	3	1	1	1	1 1/2	90	(2,286)	82 1/4	(2,089)	132	(3,353)
444136	1,400	(5,300)	60	(1,524)	3,991	(1,810)	3	3	1	1	1	1 1/2	90	(2,286)	82 1/4	(2,089)	151	(3,835)
444137	1,600	(6,057)	73	(1,854)	5,308	(2,408)	3	3	1	1	1	1 1/2	103 1/2	(2,629)	95 3/4	(2,432)	122 1/2	(3,112)
444138	1,800	(6,814)	73	(1,854)	5,704	(2,587)	3	3	1	1	1	1 1/2	103 1/2	(2,629)	95 3/4	(2,432)	135	(3,429)
444139	2,000	(7,571)	73	(1,854)	6,330	(2,871)	3	3	1	1	1	1 1/2	103 1/2	(2,629)	95 3/4	(2,432)	153	(3,886)
444140	2,200	(8,328)	73	(1,854)	6,633	(3,009)	3	3	1	1	1	1 1/2	103 1/2	(2,629)	95 3/4	(2,432)	162	(4,115)
444141	2,400	(9,085)	73	(1,854)	7,048	(3,197)	3	3	1	1	1	1 1/2	103 1/2	(2,629)	95 3/4	(2,432)	174 1/2	(4,432)
444142	2,600	(9,842)	73	(1,854)	7,463	(3,385)	3	3	1	1	1	1 1/2	103 1/2	(2,629)	95 3/4	(2,432)	187	(4,750)
444143	2,800	(10,599)	73	(1,854)	7,878	(3,573)	3	3	1	1	1	1 1/2	103 1/2	(2,629)	95 3/4	(2,432)	199 1/2	(5,067)
444144	3,000	(11,356)	73	(1,854)	8,289	(3,760)	3	3	1	1	1	1 1/2	103 1/2	(2,629)	95 3/4	(2,432)	212	(5,385)

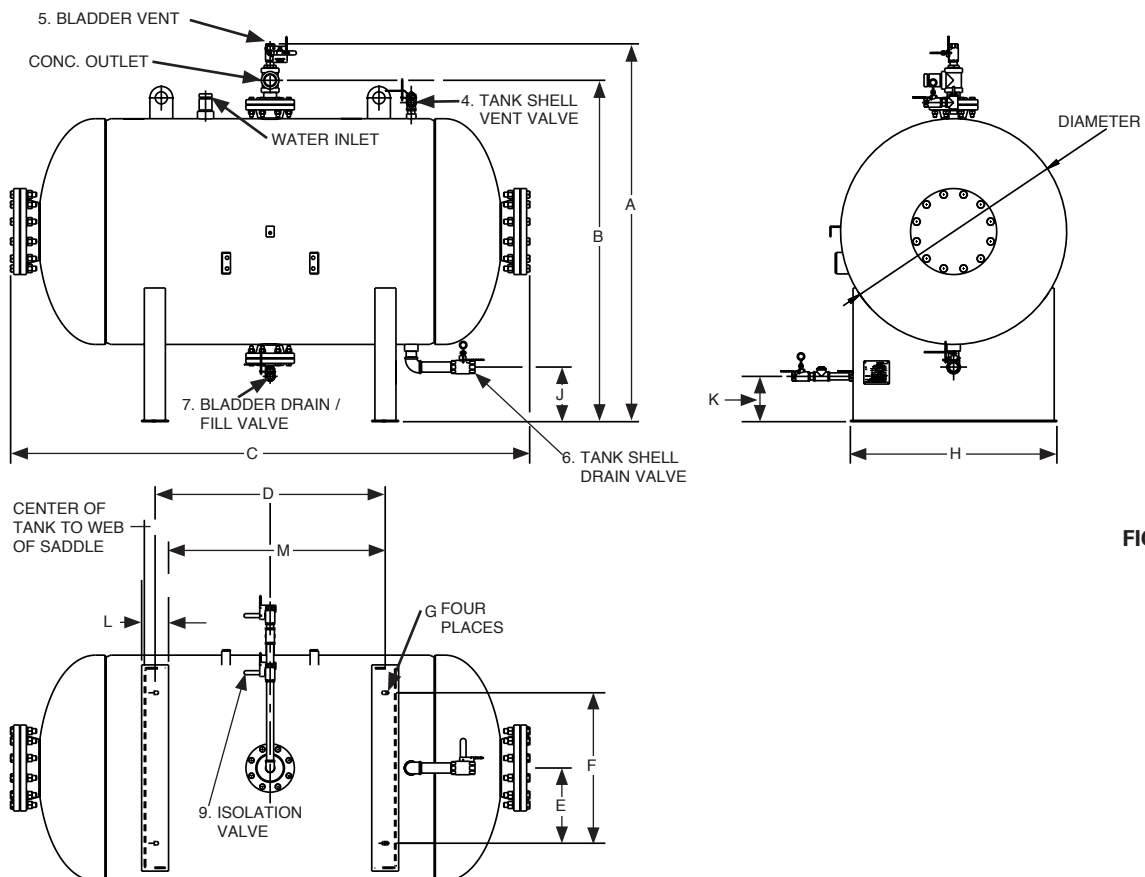

FIGURE 1
010072

Dimension Information (Continued)

Nominal Capacity	D		E		F		G		H		J		K		L		M		
	gal	(L)	in.	(mm)	in.	(mm)	in.	(mm)	in.	(mm)	in.	(mm)	in.	(mm)	in.	(mm)	in.	(mm)	
100	(379)	31 1/2	(800)	5	(127)	10	(254)	5/8 x 1 1/4	(16 x 32)	23	(584)	11 1/4	(286)	8 1/4	(210)	5	(127)	26 1/2	(673)
150	(568)	25 11/16	(652)	8	(203)	16	(406)	5/8 x 1 1/4	(16 x 32)	28	(711)	10	(254)	8 1/4	(210)	5	(127)	20 11/16	(525)
200	(757)	45 1/4	(1,149)	8	(203)	16	(406)	5/8 x 1 1/4	(16 x 32)	28	(711)	10	(254)	8 1/4	(210)	5	(127)	40 1/4	(1,022)
300	(1,136)	22 1/2	(572)	14	(356)	28	(711)	5/8 x 1 1/4	(16 x 32)	38 3/8	(975)	10	(254)	8 1/4	(210)	5	(127)	17 1/2	(445)
400	(1,514)	42 3/4	(1,086)	14	(356)	28	(711)	5/8 x 1 1/4	(16 x 32)	38 3/8	(975)	10	(254)	8 1/4	(210)	5	(127)	37 3/4	(959)
500	(1,893)	35 1/8	(892)	17	(432)	34	(864)	7/8 x 1 1/4	(22 x 32)	44	(1,118)	10	(254)	8	(203)	7	(178)	28 1/8	(714)
600	(2,271)	47 5/8	(1,210)	17	(432)	34	(864)	7/8 x 1 1/4	(22 x 32)	44	(1,118)	10	(254)	8	(203)	7	(178)	40 5/8	(1,032)
700	(2,650)	65	(1,651)	17	(432)	34	(864)	7/8 x 1 1/4	(22 x 32)	44	(1,118)	10	(254)	8	(203)	7	(178)	58	(1,473)
800	(3,028)	81 1/8	(2,061)	17	(432)	34	(864)	7/8 x 1 1/4	(22 x 32)	44	(1,118)	10	(254)	8	(203)	7	(178)	74 1/8	(1,883)
900	(3,407)	42 15/16	(1,091)	23	(584)	46	(1,168)	1 x 1 1/4	(25 x 32)	54 1/2	(1,384)	10	(254)	8	(203)	7	(178)	35 15/16	(913)
1,000	(3,785)	52 5/8	(1,337)	23	(584)	46	(1,168)	1 x 1 1/4	(25 x 32)	54 1/2	(1,384)	10	(254)	8	(203)	7	(178)	45 5/8	(1,159)
1,200	(4,542)	66 7/8	(1,699)	23	(584)	46	(1,168)	1 x 1 1/4	(25 x 32)	54 1/2	(1,384)	10	(254)	8	(203)	7	(178)	59 7/8	(1,521)
1,400	(5,300)	66	(1,676)	23	(584)	46	(1,168)	1 x 1 1/4	(25 x 32)	54 1/2	(1,384)	10	(254)	8	(203)	7	(178)	59	(1,499)
1,600	(6,057)	48 1/2	(1,232)	29	(737)	46	(1,168)	1 x 1 1/4	(25 x 32)	66 1/4	(1,683)	10	(254)	7 1/2	(191)	9	(229)	39 1/2	(1,003)
1,800	(6,814)	60 5/8	(1,540)	29	(737)	58	(1,473)	1 x 1 1/4	(25 x 32)	66 1/4	(1,683)	10	(254)	7 1/2	(191)	9	(229)	51 5/8	(1,311)
2,000	(7,571)	72 15/16	(381)	29	(737)	58	(1,473)	1 x 1 1/4	(25 x 32)	66 1/4	(1,683)	10	(254)	7 1/2	(191)	9	(229)	63 15/16	(1,624)
2,200	(8,328)	63 3/4	(1,853)	29	(737)	58	(1,473)	1 x 1 1/4	(25 x 32)	66 1/4	(1,683)	10	(254)	7 1/2	(191)	9	(229)	54 3/4	(1,391)
2,400	(9,085)	100 1/2	(2,553)	29	(737)	58	(1,473)	1 x 1 1/4	(25 x 32)	66 1/4	(1,683)	10	(254)	7 1/2	(191)	9	(229)	91 1/2	(2,324)
2,600	(9,842)	113 1/16	(2,872)	29	(737)	58	(1,473)	1 x 1 1/4	(25 x 32)	66 1/4	(1,683)	10	(254)	7 1/2	(191)	9	(229)	104 1/16	(2,643)
2,800	(10,599)	125 9/16	(3,189)	29	(737)	58	(1,473)	1 x 1 1/4	(25 x 32)	66 1/4	(1,683)	10	(254)	7 1/2	(191)	9	(229)	116 9/16	(2,961)
3,000	(11,356)	137 15/16	(3,504)	29	(737)	58	(1,473)	1 x 1 1/4	(25 x 32)	66 1/4	(1,683)	10	(254)	7 1/2	(191)	9	(229)	128 15/16	(3,275)

Dimension and Installation Notes:

- Dimensions listed are approximate and subject to change without notice.
- Foam Concentrate Discharge Pipe
 - Tank sizes 50 gal to 400 gal (189 L to 1,514 L):
2 in. Female NPT or Grooved
 - Tank sizes 500 gal to 3,000 gal (1,893 L to 11,356 L):
3 in. Female NPT or Grooved
- Water Inlet Pipe
 - Tank sizes 50 gal to 400 gal (189 L to 1,514 L):
2 in. Female NPT or Grooved
 - Tank sizes 500 gal to 3,000 gal (1,893 L to 11,356 L):
3 in. Female NPT or Grooved
- Rooms or buildings intended to house a bladder tank should have accommodations for the removal of the internal center tube(s). Center tubes are approximately the full height and/or width of the bladder tank.

Ordering Information

Please specify the following when ordering:

- Part Number for required bladder tank size and orientation (See Ordering Part Numbers Table)
- Foam concentrate type to be used ¹
- One option from each of the following categories ²:

Exterior Paint	Option 1: Standard Option 2: CR Epoxy
Exterior Paint Color ³	Option 1: Red (RAL 3001) Option 2: Blue (RAL 5019) Option 3: Yellow (RAL 1021) Option 4: Other ⁴
Trim Piping / Valve Material	Option 1: Brass Piping/Brass Valves Option 2: 316 SS Piping/ SS Valves
Sight Gauge	Option 1: Sight Gauge Included Option 2: No Sight Gauge
Thermal Relief Valve ⁵	Option 1: No Thermal Relief Valve Option 2: Thermal Relief Valve Included
Packaging	Option 1: Domestic Packaging Option 2: Export Crating

Ordering Notes:

1. Tanks will be marked as UL Listed and/or FM Approved based on the foam concentrate type specified. If foam concentrate type is not specified, the tank will not be marked as UL Listed or FM Approved.
2. If an option is not specified from a category, Option 1 will be used as the default.
3. UL Listing of paint systems is color-specific. The Red, Blue, and Yellow color shade options shown above are UL Listed. Contact TFPP Technical Services to determine if other color shades are UL Listed.
4. If "Other" is selected, the specific paint shade required must be supplied. Availability of the paint shade selected may impact lead time.
5. Set pressure is 175 psi (12.1 bar). Set pressure cannot exceed the design pressure of the tank per ASME code.

Expediting Service

Selected sizes of SKUM bladder tanks, including most of the standard options listed above, are available for optional expediting service. These tanks can be shipped in two weeks or less after order confirmation. See the list of ordering part numbers for the specific sizes eligible for this service. Due to availability, expedited tanks are only available in RAL3001 Red. Contact Tyco Fire Protection Products Technical Services or a SKUM Regional Sales Manager for additional information and limitations on this service.

Bladder Tank Ordering Part Numbers

Nominal Capacity gal	(L)	Part Number	Expediting Available
100	(379)	444044	
150	(568)	444045	
200	(757)	444046	√
300	(1,136)	444047	√
400	(1,514)	444048	
500	(1,893)	444049	√
600	(2,271)	444050	
700	(2,650)	444051	
800	(3,028)	444052	
900	(3,407)	444053	
1,000	(3,785)	444054	
1,200	(4,542)	444055	
1,400	(5,300)	444056	
1,600	(6,057)	444057	
1,800	(6,814)	444058	
2,000	(7,571)	444059	
2,200	(8,328)	444060	
2,400	(9,085)	444061	
2,600	(9,842)	444062	
2,800	(10,599)	444063	
3,000	(11,356)	444064	

Flange Adapters

Tyco Fire Protection Products Figure 71 Flange Adapters are available to adapt the grooved fittings supplied with SKUM bladder tanks to flanged piping for field installation. The sizes listed below have a maximum pressure rating of 300 psi (20.7 bar). The flange adapter body is ductile iron and utilizes a Grade "E" EPDM gasket. Finished with Red (RAL 3000) non-lead paint.

Ordering Information (Continued)

Adapter Size		Recommended Flange Mating Bolts				Approx. Weight lb (kg)	Ordering Part Number
Grooved in. (mm)	ANSI Flange (DIN)	Size Dia x L in.	Qty.	Bolt Torque Range lb-ft (N-m)			
2 (50)	2 (DN50)	5/8 x 3	4	110 – 140 (149 – 190)	3.0 (1.4)	7120TS	
2 1/2 (65)	2 1/2 (DN65)	5/8 x 3	4	110 – 140 (149 – 190)	5.0 (2.3)	7125TS	
3 (80)	3 (DN80)	5/8 x 3	4	110 – 140 (149 – 190)	5.6 (2.5)	7130TS	
4 (100)	4 (DN100)	3/4 x 3 1/2	8	220 – 250 (298 – 339)	7.0 (3.2)	7140TS	
6 (150)	6 (DN150)	3/4 x 3 1/2	8	220 – 250 (298 – 339)	10.0 (4.5)	7160TS	
8 (200)	8 (DN200)	3/4 x 3 1/2	8	220 – 250 (298 – 339)	16.6 (7.5)	7180TS	

Touch Up Paint

Touch up paint for Red (RAL 3001) equipment is available in a convenient 7 ounce spray can. Touch up paint for other colors is not available in spray cans. Contact Tyco Fire Protection Products Technical Services for touch up paint in other colors.

Red (RAL 3001) Touch Up Paint – Part Number: 405581.

Custom Engineering

SKUM Bladder Tanks can be customized to accommodate a variety of special requirements, including but not limited to ladders, platforms, alternate materials of construction, higher design pressures, space constraints, larger capacities, and seismic rated tanks. Contact Tyco Fire Protection Products Technical Services or a SKUM Regional Sales Manager for additional information or to obtain a quote. **Note:** UL Listed tanks are limited to maximum capacities of 4,000 gal (15,142 L) for horizontal tanks with maximum working pressures of 175 psi to 250 psi (12.1 bar to 17.2 bar). FM Approved tanks are limited to maximum capacities of 3,000 gal (11,356 L).

Note: The converted values provided in this document are for nominal reference only and do not reflect an actual measurement.

SKUM and the product names listed in this material are marks and/or registered marks. Unauthorized use is strictly prohibited.