

Fog/Jet Monitor - Electric FJM-EL

(replaces datasheets: 1011/139/140/141 and 1011/124/130)

General description

Powerful fire extinguishing monitor with exceptionally good flow characteristics. Remote control operation. Electric motor driven elevation and rotation movement and solenoid valve operated fog/jet pattern adjustment.

Application description

Intended for fixed mounting, it is designed for an optimised delivery of water or foam from a solid jet to a fog pattern by remote control.

Product features

- Wide capacity range
- Adjustable flow to nominal capacity
- Compact, balanced design
- Easily manoeuvred due to low friction bearings
- Long throw length
- Manufactured from stainless steel and bronze
- Adjustable stream pattern
- Corrosion resistant construction of stainless steel and bronze
- Integrated electrical junction box
- Available with EEx (e) and (de) electrical equipment, according to ATEX guidelines

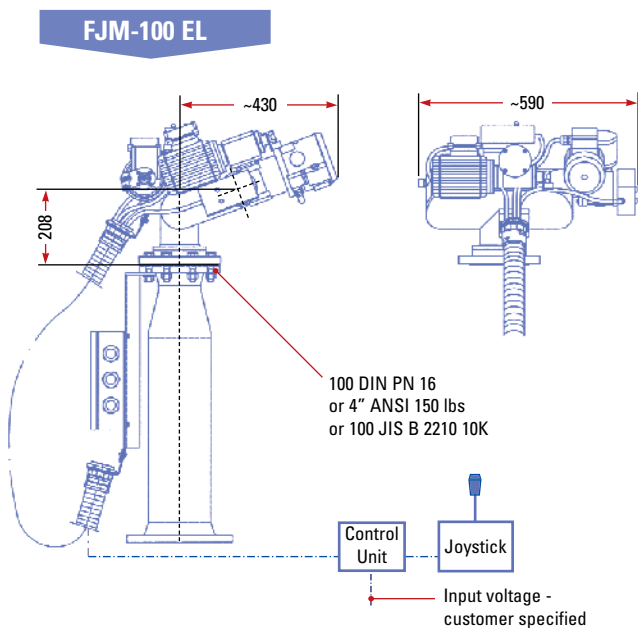

FJM-100 Monitor - Range of Jet

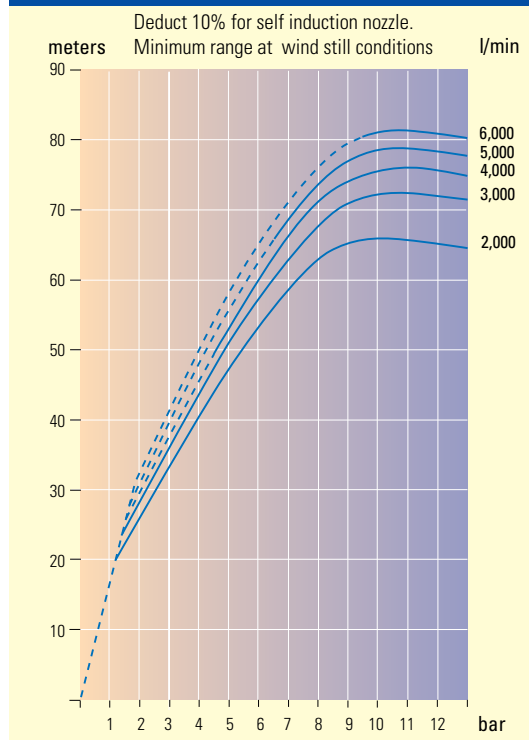

$$\text{Reaction force (N)} = 0.233 \times Q \text{ (l/min)} \times \sqrt{p \text{ (bar)}}$$



tyco
Fire Suppression
& Building Products

www.skum.com

Technical changes reserved without notice
Copyright © 2009 Tyco Fire Suppression & Building Products

TYLENSKUM01 / v1.0

Fog/Jet Monitor - Electric

FJM-EL

Datasheet 1011/170

Page 2 of 4

(replaces datasheets: 1011/139/140/141 and 1011/124/130)

Connections

- Foam/water inlet: flanged according to DIN PN16 or ANSI 150lbs

Optional components

- Control and operating panel, custom built solutions on request
- Built-in inductor optional on all models
- Power supply from 12VDC to 440V AC available
- Optional suction hose and valve

Listings or approvals

- Det Norske Veritas (DNV)
- EN 13565-2 approved by CNBOP; FJM-100EL
- Lloyds Register of Shipping (LRS)
- Bureau Veritas (BV)
- China National Test Centre Approval (TFRI); FJM-100EL, FJM-150EL
- Russian Maritime Register of Shipping (RMRS); FJM-100EL, FJM-150EL
- Russian State Fire Academy

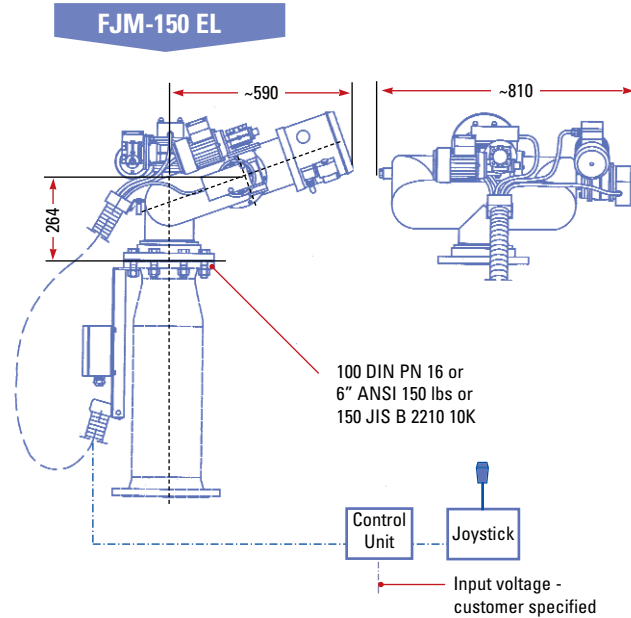

Order information

Description	Part No.
FJM-100 C EL Man DIN	1634C10103
FJM-100 C EL Man ANSI	1634C10202
FJM-100 C EL MV DIN	1634C10148
FJM-100 C EL MV ANSI	1634C10247
FJM-100 C EL S MV DIN, excluding suction hose	1634C10153
FJM-100 C EL S MV ANSI, excluding suct'n hose	1634C10252
FJM-100 C EL Man Exe DIN	1635C10103
FJM-100 C EL Man Exe ANSI	1635C10204
FJM-100 C EL MV Ex DIN	1635C10153
FJM-100 C EL MV Ex ANSI	1635C10254
FJM-100 C EL MV Exde DIN	1636C10152
FJM-100 C EL MV Exde ANSI	1636C10253
FJM-100 Suction Hose 2" 3mtr	161010606
FJM-150 C EL MV DIN/ANSI/JIS	1634C10142
FJM-150 C EL MV Ex DIN/ANSI	1635C15145
FJM-150 C EL MV Exde DIN/ANSI/JIS	1636C15144
FJM-150 Suction Hose 2" 3mtr	161015608
FJM-200 C EL MV DIN	163420144
FJM-200 C EL MV ANSI	163420243

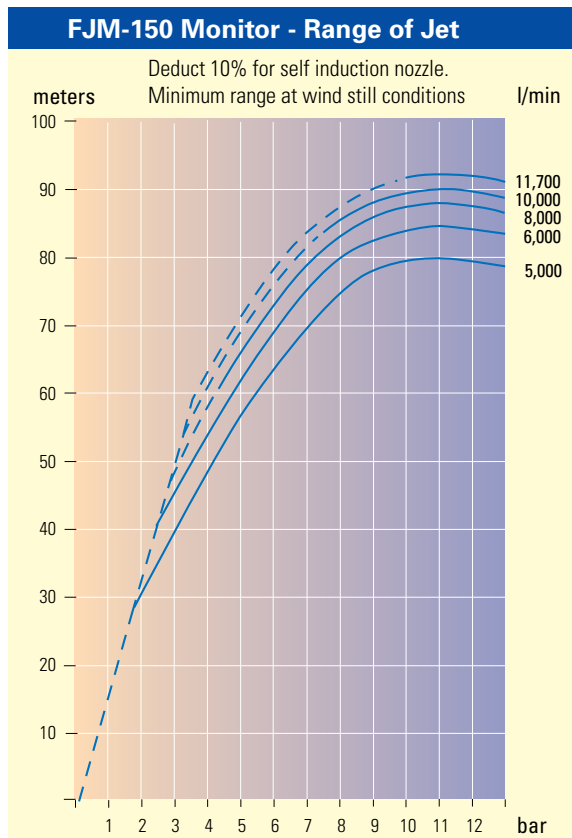

tyco
Fire Suppression
& Building Products

www.skum.com

Technical changes reserved without notice
Copyright © 2009 Tyco Fire Suppression & Building Products

TYLENSKUM01 / v1.0

Fog/Jet Monitor - Electric

FJM-EL

(replaces datasheets: 1011/139/140/141 and 1011/124/130)

FJM-200 EL

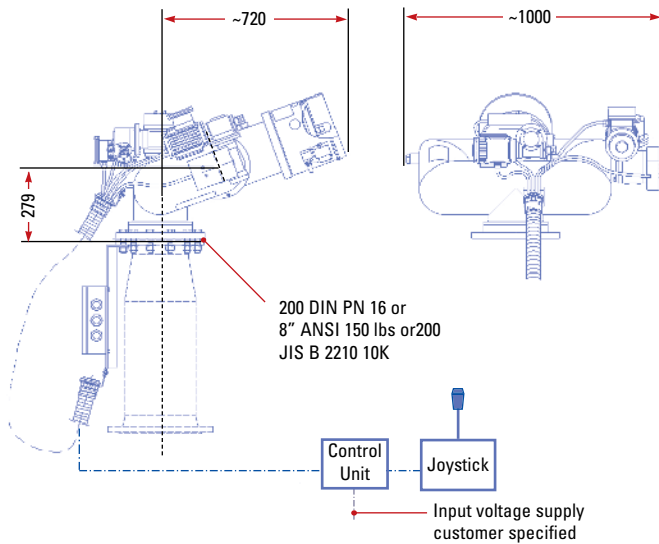

Performance Data			
FJM Series - Standard			
Size	100	150	200
Water capacity	6,000 l/min	11,700 l/min	20,000 l/min
Design pressure	16 bar	16 bar	13 bar
Rotation	±165°	±165°	±165°
Elevation	-70°/+70°	-70°/+70°	-60°/+70°
Weight	69 kg / 152 lbs	98 kg / 216 lbs	139 kg / 306 lbs

FJM-S Series - Built-in inductor			
Size	100	150	200
Water capacity	6,000 l/min	11,700 l/min	20,000 l/min
Foam capacity max.	320 l/min	600 l/min	600 l/min
Elevation	-45° / +70°	-45° / +70°	-45° / +70°
Suction connection	2" BSP male	2" BSP male	2" BSP male
Weight	72 kg / 159 lbs	101 kg / 222 lbs	145 kg / 319 lbs

FJM Monitors - Average Fog Pattern (in still air)

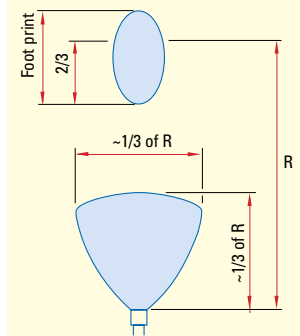

FJM-200 Monitor - Range of Jet

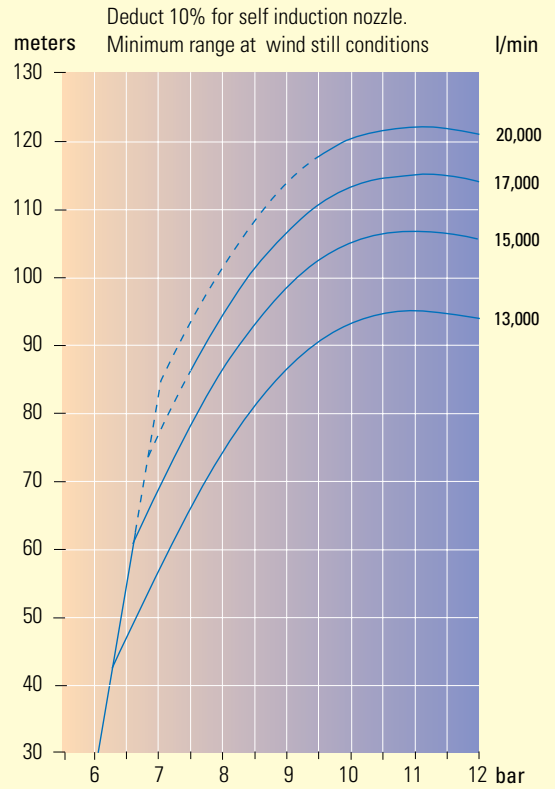

$$\text{Reaction force (N)} = 0.233 \times Q \text{ (l/min)} \times \sqrt{p \text{ (bar)}}$$

FJM Monitors - Capacity Ranges

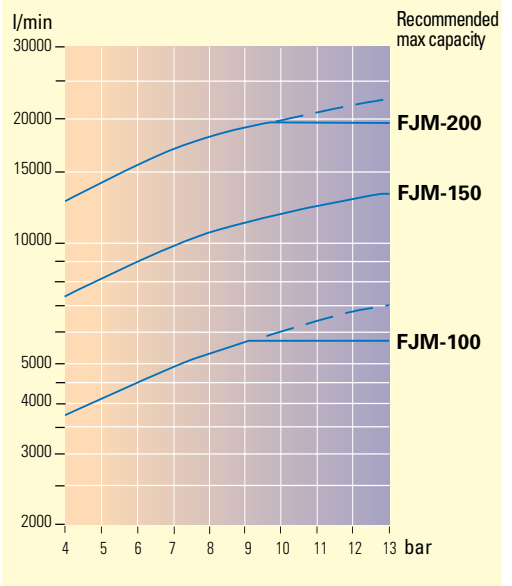

tyco
Fire Suppression
& Building Products

www.skum.com

Technical changes reserved without notice
Copyright © 2009 Tyco Fire Suppression & Building Products

TYLENSKUM01 / v1.0

Fog/Jet Monitor - Electric FJM-EL

Datasheet 1011/170

Page 4 of 4

(replaces datasheets: 1011/139/140/141 and 1011/124/130)



tyco
Fire Suppression
& Building Products

www.skum.com

Technical changes reserved without notice
Copyright © 2009 Tyco Fire Suppression & Building Products

TYLENSKUM01 / v1.0

Datasheet Ref: SK1002