

(replaces datasheets 1010/21 and 22)

General description

Skum TP proportioners guarantee accurate foam proportioning over a wide range of flow and pressure conditions; manufactured in bronze, they are maintenance-free and used in a wide range of industrial and marine environments.

Application description

The TP proportioner is used in conjunction with bladder tanks to supply accurate foam delivery to fire monitors and deluge systems. The TP is used in combination with the Skum bladder tank, MTB.

Product features

- Designed to meet the requirements of EN13565-1 and NFPA 16 Ch 4
- Factory set to deliver accurate foam proportioning up to 6%
- Maintenance free
- Bronze, corrosion resistant construction
- Wafer type water connection

Connections

- Water: wafer mounted between flanges, see performance data table
- Foam: flanged to fit DIN PN16 or ANSI 150 lbs or screw-threaded BSP, see performance data table

Listings and approvals

- Tested according to and complying with EN 13565-1
- Det Norske Veritas (DNV)
- Bureau Veritas (BV)
- Chinese National Test Centre Approval (TFRI); TP-100
- Russian State Fire Academy
- Russian Maritime Register of Shipping (RMRS)

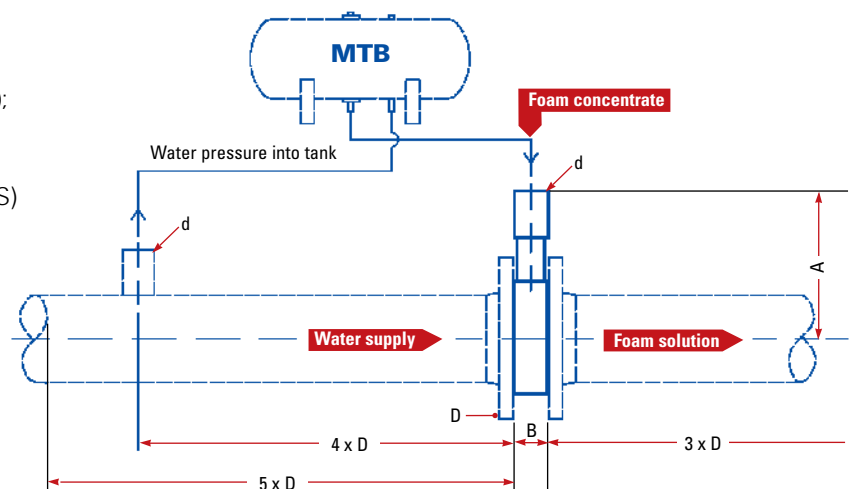
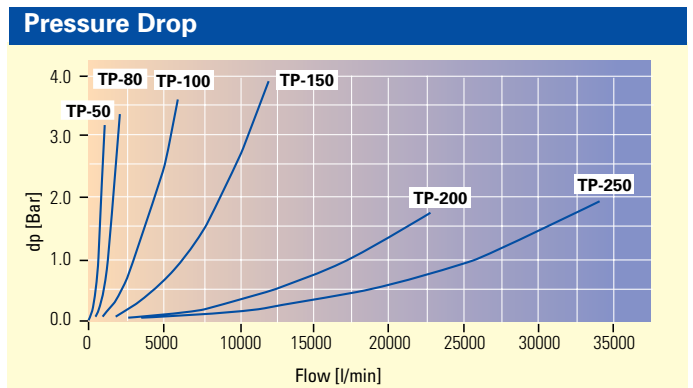

(replaces datasheets 1010/21 and 22)

Fitting

The tank proportioner is designed to fit between flanges and is only to be used with a bladder tank system.

A minimum of five diameters (D) of straight pipe is required in the water line before entering the proportioner and three diameters (D) after the proportioner. Minimum distance for water pressure into tank upstream of the TP is four diameters (D) and maximum distance is 10 meters.

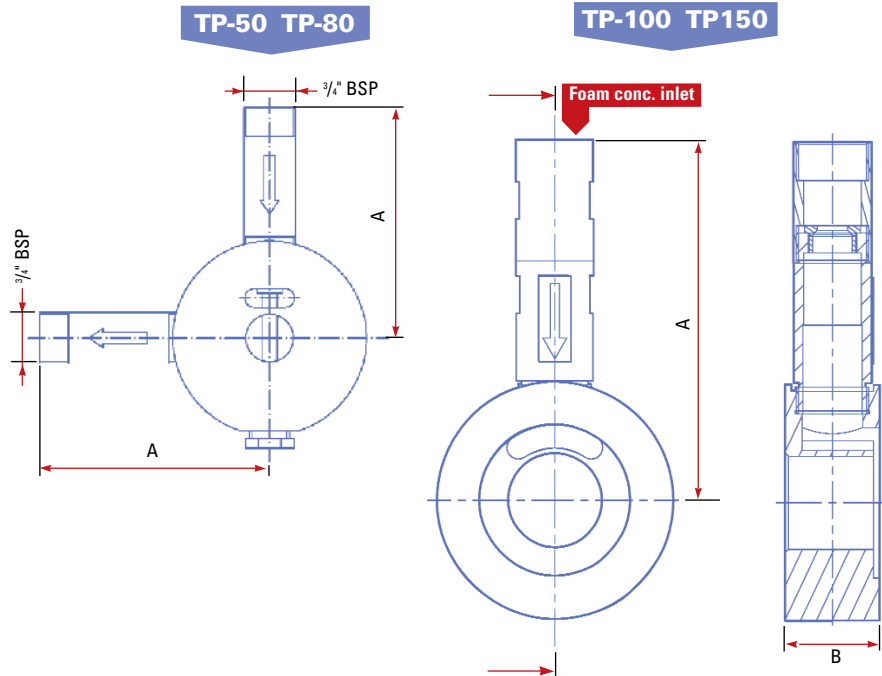

Order information

Description	Part No.	Description	Part No.
TP-50	124005105	TP-200 DIN/ANSI 2%	124320103E
TP-80	124008107	TP-200 DIN/ANSI 1%	124320103B
TP-100 BSP 3%	124310102A	TP-200 DIN/ANSI 6%	124320103J
TP-100 BSP 2%	124310004E	TP-250 DIN 3%	124325104A
TP-100 BSP 1%	124310004B	TP-250 DIN 2%	124325104E
TP-100 BSP 6%	124310004J	TP-250 DIN 1%	124325104B
TP-150 BSP 3%	124315007A	TP-250 DIN 6%	124320104J
TP-150 BSP 2%	124315007E	TP-250 ANSI 3%	124325206A
TP-150 BSP 1%	124315007B	TP-250 ANSI 2%	124325206E
TP-150 BSP 6%	124315007J	TP-250 ANSI 1%	124325206B
TP-200 DIN/ANSI 3%	124320103A	TP-250 ANSI 6%	124325206J

Dimensions TP

Type	A mm	B mm
TP-50	125	37
TP-80	140	37
TP-100	239	62
TP-150	262	62
TP-200	337	82
TP-250	365	82

Performance Data

Type	Connection		Capacity				Proportioner k-factor	Weight		Max. Working Pressure		Materials
	d*	D	Min. l/min	Min. USGPM	Max. l/min	Max. USGPM		kg	lbs	bar	psi	
TP-50	3/4" BSP	50 / 2"	125	33	800	211	450	6	13	16	235	Bronze (Cu88Sn12)
TP-80	3/4" BSP	80 / 3"	300	79	2,000	528	1,110	10	22	16	235	Bronze (Cu88Sn12)
TP-100	1 1/2" BSP female and Grooved 50 (2")	100 / 4"	770	203	6,000	1,585	4,040	12	26	16	235	Bronze (Cu88Sn12)
TP-150	1 1/2" BSP female and Grooved 50 (2")	150 / 6"	1,500	396	12,000	3,170	7,070	15	33	16	235	Bronze (Cu88Sn12)
TP-200	50 / 2"	200 / 8"	2,875	760	22,750	6,001	17,255	32	71	16	235	Bronze (Cu88Sn12)
TP-250	80 / 3"	250 / 10"	5,100	1,347	34,100	9,009	27,060	42	92	16	235	Bronze (Cu88Sn12)

*Flanges to fit DIN PN 16 or ANSI 150 lbs
 1 bar = 0,1 MPa = 14,5 psi
 Q l/min. ÷ √P bar = k-factor



www.skum.com

Technical changes reserved without notice
 Copyright © 2009 Tyco Fire Suppression & Building Products

TYLENSKUM022 / v1.0

Datasheet Ref. SK1009