

Model MTB-ASME Horizontal Pre-Piped Bladder Tanks

Features

- Pre-piped configurations with a wide selection of proportioner sizes, including the SKUM TPW-150 MK2 for closed-head sprinkler systems
- Includes all components required for use in an automatic or manually operated system
- UL Listed and FM Approved for use with various SKUM proportioners and foam concentrates
- 175 psi (12.1 bar) maximum allowable working pressure (design pressure)
- Nominal capacities up to 11,355 liters with larger tanks available on special request
- Choice of Standard or Corrosion-Resistant Epoxy exterior paint, available in a variety of colors
- Optional sight gauge and thermal pressure relief valves available

Application

The SKUM MTB-ASME Horizontal Pre-Piped Bladder Tank is a complete balanced pressure proportioning system inclusive of a proportioner and all of the valves and piping required for either manual or automatic operation. These tanks are intended for use where it is desirable to have the proportioning system pre-assembled with fixed dimensions known, eliminating field assembly of loose components and uncertainty in the layout of the foam equipment room. SKUM pre-piped bladder tanks can be used with most SKUM foam concentrates and any suitable discharge device to complete the foam system.

SKUM Pre-Piped Bladder Tanks require only a pressurized water supply for operation. No other external power is required. As with standard SKUM bladder tanks, they can be used in a variety of applications, including aircraft hangars, foam-water sprinkler systems, truck loading racks, and helipads.

Description

The SKUM Horizontal Pre-Piped Bladder Tank is a steel pressure vessel which stores foam concentrate contained within an elastomeric bladder. The concentrate is discharged from the tank by incoming water applying pressure to the bladder. This applied energy is transferred to the foam concentrate, supplying pressurized foam concentrate to the proportioner.

Trim Piping and Connections

SKUM Horizontal Pre-Piped Bladder Tanks are available in models up to 11,355 liters. All models are piped for top discharge of foam concentrate and include a stainless steel SKUM Hydraulic Concentrate Control Valve. **Note:** For automatic operation, the sensing line to the SKUM Hydraulic Concentrate Control Valve must be piped in the field.

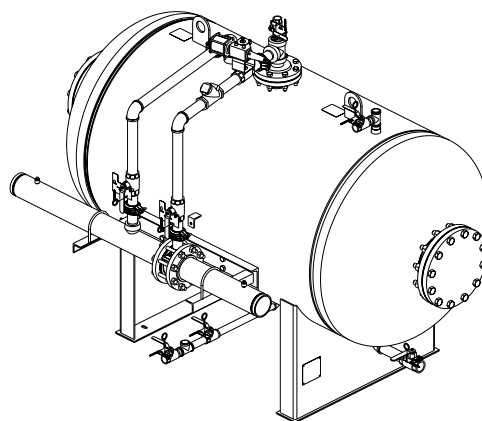

010118

The proportioner and carbon steel spool pipes are factory installed with the direction of flow from left to right when viewed from the piping side of the tank. Spool pipes are sized to match the proportioner selected and lengths are a minimum of five pipe diameters upstream and two and a half pipe diameters downstream of the proportioner. The supplied spool pipes are grooved for use with grooved couplings. Adapters to facilitate use of flanged connections are available separately.

The pre-piped trim consists of brass pipe with bronze manual ball valves and includes all valves required for manual or automatic operation. All manual valves are clearly identified by permanently attached nameplates and can be secured in position with included ring pins and tamper seals. To facilitate automatic operation, a SKUM Hydraulic Concentrate Control Valve is factory installed in the foam concentrate discharge piping.

Protective Coatings

All SKUM Horizontal Pre-Piped Bladder Tanks feature a high-build epoxy internal coating. Exterior paint is available in two grades: Standard and Corrosion-Resistant Epoxy (Epoxy CR). Paint systems used on SKUM Horizontal Pre-Piped Bladder Tanks have been subjected to and passed salt spray corrosion testing per ASTM B117-90. Standard paint has been tested to a minimum of 240 hours in accordance with UL 162, UL 139, and FM 5130. Epoxy CR paint has been tested to a minimum of 3,000 hours and is suitable for marine and offshore use.

Support and Mounting

Horizontal tanks are supported by two saddles with slotted holes for mounting. Refer to dimensional drawings for mounting hole spacing.

Horizontal Tanks

Diameter	Nominal Capacity	Mounting Slot Size
24 in. to 42 in. (610 mm to 1,067 mm)	100 gal to 400 gal (379 L to 1,514 L)	5/8 in. x 1 1/4 in. (16 mm x 32 mm)
48 in. (1,219 mm)	500 gal to 800 gal (1,893 L to 3,028 L)	7/8 in. x 1 1/4 in. (22 mm x 32 mm)
60 in. to 72 in. (1,524 mm to 1,829 mm)	900 gal to 3,000 gal (3,407 L to 11,355 L)	1 in. x 1 1/4 in. (25 mm x 32 mm)

Description (Continued)

Support and Mounting (Continued)

All included piping and valves are supported by the tank. No additional support or bracing of piping is required under normal circumstances. Included piping is not designed to support loading from external piping connections. Appropriate piping supports should be used on field piping to avoid damage.

Each tank is fitted with two lifting lugs designed to lift the empty weight of the tank with a minimum safety factor of 2 when utilizing appropriate slings rigged at a lifting angle of not less than 30 degrees from horizontal. All lifting lugs have a minimum clear hole size of 2 in. (50 mm).

Internal Components

SKUM Horizontal Pre-Piped Bladder Tanks contain an elastomeric bladder that has been approved for use by Underwriter's Laboratory and FM Approvals with various SKUM foam concentrates. Horizontal SKUM Pre-Piped Bladder Tanks utilize a center tubes to facilitate agent discharge. Center tubes are constructed of materials compatible with SKUM foam concentrates. Horizontal tanks utilize two center tubes, one oriented horizontally and one oriented vertically, connected by a cross fitting.

Sight Gauge

A sight gauge is available as an optional accessory for SKUM Horizontal Pre-Piped Bladder Tanks for estimation of the fill level in the tank. The sight gauge is equipped with a clear 1 in. (25 mm). PVC tube. The sight gauge is shipped as a loose item and must be assembled on the tank during installation

Thermal Relief Valve

A thermal relief valve is available as an option for SKUM bladder tanks. A thermal relief valve should be used when the bladder tank will be stored in an isolated/hydraulically locked condition in order to relieve pressure due to thermal expansion. This valve is factory set to 175 psi (12 bar) and it is recommended that the design pressure of the system be maintained at least 5 psi (0.34 bar) or 10% below the set pressure of the valve to avoid seat leakage and early valve maintenance. This valve is NOT a substitute for a properly sized ASME pressure relief valve to protect the entire system from overpressure.

ASME Information

The SKUM MTB-ASME Horizontal Pre-Piped Bladder Tank is designed and constructed in accordance with the latest revisions to ASME Code Section VIII, Division 1 for unfired pressure vessels with a maximum allowable working pressure (MAWP) of 175 psi (12.1 bar) and tested to the pressure specified by the applicable codes and standards. Tanks designed to ASME code are tested to at least 230 psi (15.9 bar). CE marked tanks are tested to at least 255 psi (17.6 bar). All SKUM bladder tanks are constructed of steel complying with ASME specifications. Tank heads are 2:1 elliptical unless otherwise specified.

All SKUM Horizontal Pre-Piped Bladder Tanks include a permanently affixed stainless steel ASME data plate. At a minimum, the data plate includes the following information: year of manufacture, maximum allowable working pressure (MAWP), nominal volume, part number, National Board number, minimum material thickness, minimum design metal temperature (MDMT), and type of head used.

Approvals and Certifications

SKUM Horizontal Pre-Piped Bladder Tanks are UL Listed and FM Approved for use with various SKUM foam concentrates. The UL mark and/or FM Approval diamond are applied at the factory along with a label identifying the SKUM foam concentrate for use in the tank.

Every tank bears a permanently affixed ASME data plate showing the National Board number which identifies the tank as compliant with ASME code Section VIII, Division 1 for unfired pressure vessels.

SKUM Horizontal Pre-Piped Bladder Tanks 200 gal (757 L) and larger are CE marked in conformance with the European Pressure Equipment Directive, 2014/68/EU. Under European Pressure Equipment Directive 2014/68/EU, tanks smaller than 200 gal (757 L) are acceptable based on sound engineering practices of ASME code and cannot be CE marked.

Operation and Maintenance

Refer to the SKUM Bladder Tank Operation and Maintenance Manual for detailed procedures on installation, operation, inspection, and maintenance. A printed copy of this manual is included with every tank.

Valve Position Information

Valve* No.	Valve Description	Normal Valve Position	
		Manual System	Automatic System
1.	Manual Foam Concentrate Shutoff	N.C.**	N.O.***
2.	Water Supply Shut-Off	N.C.	N.O.
3.	Sight Gauge Shut-Off	N.C.	N.C.
4.	Tank Shell Vent Valve	N.C.	N.C.
5.	Bladder Vent Valve	N.C.	N.C.
6.	Tank Shell Drain Valve	N.C.	N.C.
7.	Bladder Drain/Fill Valve	N.C.	N.C.
8.	Automatic Foam Concentrate Isolation	N.O.	N.C.
9.	Isolation Valve	N.C.	N.C.

*Reference dimensional drawings for valve locations

**N.C. – Normally Closed

***N.O. – Normally Open

Dimension and Installation Notes:

- Dimensions listed are approximate and subject to change without notice.
- Foam Concentrate Discharge Pipe
 - Tank sizes 100 gal to 400 gal (379 L to 1,514 L):
2 in. Female NPT or Grooved
 - Tank sizes 500 gal to 3,000 gal (1,893 L to 11,355 L):
3 in. Female NPT or Grooved
- Water Inlet Pipe
 - Tank sizes 100 gal to 400 gal (379 L to 1,514 L):
2 in. Female NPT or Grooved
 - Tank sizes 500 gal to 3,000 gal (1,893 L to 11,355 L):
3 in. Female NPT or Grooved
- Rooms or buildings intended to house a bladder tank should have accommodations for the removal of the internal center tube(s). Center tubes are approximately the full height and/or width of the bladder tank.
- Spool pipe sizes correspond to the proportioner size.
- Spool pipes are supplied ready to pipe using grooved fittings. Adapters for use with flange connections available separately.

Horizontal Bladder Tank

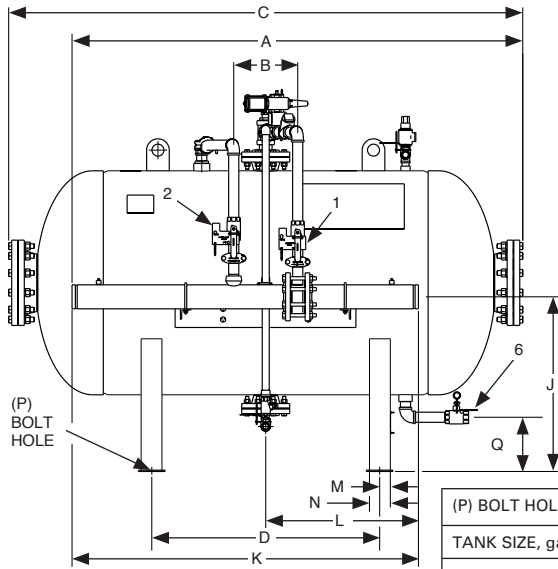

(P) BOLT HOLE (SLOT)	
TANK SIZE, gal	IN. (mm)
100 - 400	5/8 x 1 1/4 (16 x 32)
500 - 800	7/8 x 1 1/4 (22 x 32)
900 - 3000	1 x 1 1/4 (25 x 32)

Ordering Information

Please specify the following when ordering:

- Part number for required bladder tank size and orientation (see Ordering Table)
- Foam concentrate type to be used ¹
- One option from each of the following categories ²⁻³:

Proportioner Size/Style (See Ordering Table)	
Option 1	2 in. (50 mm) DN50 Threaded
Option 2	2 1/2 in. (65 mm) DN65 Threaded
Option 3	3 in. (80 mm) DN80 Between the Flange (wafer-style)
Option 4	4 in. (100 mm) DN100 Between the Flange (wafer-style)
Option 5	6 in. (150 mm) DN150 Between the Flange (wafer-style)
Option 6	8 in. (200 mm) DN200 Between the Flange (wafer-style)
Option 7	SKUM TPW-150 MK2

Exterior Paint	Option 1: Standard Option 2: CR Epoxy
Exterior Paint Color ⁴	Option 1: Red (RAL 3001) Option 2: Blue (RAL 5019) Option 3: Yellow (RAL 1021) Option 4: Other ⁵
Sight Gauge	Option 1: Sight Gauge Included Option 2: No Sight Gauge
Thermal Relief Valve ⁶	Option 1: No Thermal Relief Valve Option 2: Thermal Relief Valve Included
Packaging	Option 1: Domestic Packaging Option 2: Export Crating

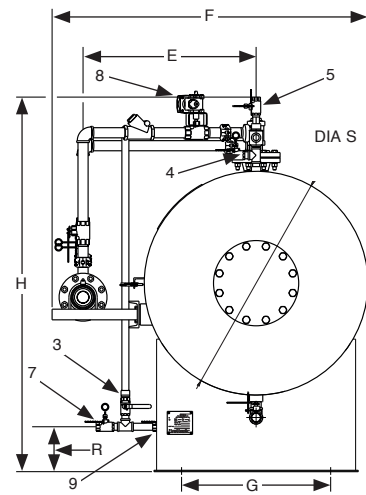

FIGURE 1
010117

Ordering Notes:

- Tanks will be marked as UL Listed and/or FM Approved based on the foam concentrate type specified. Orders for SKUM Horizontal Pre-Piped Bladder Tanks will not be processed unless foam concentrate type is specified as this information is required to properly manufacture the proportioner.
- Orders for SKUM Horizontal Pre-Piped Bladder Tanks will not be processed if a proportioner size is not specified. See the Ordering Table for standard tank size and proportioner combinations.
- For all other options categories, if an option is not specified, Option 1 will be used as the default.
- UL Listing of paint systems is color-specific. The Red, Blue, and Yellow color shade options shown above are UL Listed. Contact TFPF Technical Services to determine if other color shades are UL Listed.
- If "Other" is selected, the specific paint shade required must be supplied. Availability of the paint shade selected may impact lead time.
- Set pressure is 175 psi (12.1 bar). Set pressure cannot exceed the design pressure of the tank per ASME code.

Expediting Service

Selected sizes of SKUM bladder tanks, including most of the standard options listed above, are available for optional expediting service. These tanks can be shipped in three weeks or less after order confirmation. See the Ordering Table for the specific sizes eligible for this service. Expedited tanks are only available in RAL3001 Red. Contact Johnson Controls or a SKUM Regional Sales Manager for additional information and limitations on this service.

Ordering Information (Continued)

Ordering Table

Horizontal Bladder Tanks		Standard Proportioner Options							
Capacity gal (L)	Part Number	Expediting Available	2 in. (50 mm)	2.5 in. (65 mm)	3 in. (80 mm)	4 in. (100 mm)	6 in. (150 mm)	8 in. (200 mm)	TPW 150 MK2
100 (379)	444164		√	√	√	√			
150 (568)	444165				√	√	√		
200 (757)	444166	√			√	√	√		√
300 (1,136)	444167	√			√	√	√		√
400 (1,514)	444168					√	√		√
500 (1,893)	444169	√				√	√	√	√
600 (2,271)	444170					√	√	√	√
700 (2,650)	444171					√	√	√	√
800 (3,028)	444172					√	√	√	√
900 (3,407)	444173					√	√	√	√
1,000 (3,785)	444174					√	√	√	√
1,200 (4,542)	444175					√	√	√	√
1,400 (5,299)	444176					√	√	√	√
1,600 (6,056)	444177					√	√	√	√
1,800 (6,813)	444178					√	√	√	√
2,000 (7,570)	444179					√	√	√	√
2,200 (8,327)	444180							√	√
2,400 (9,084)	444181							√	√
2,600 (9,841)	444182							√	√
2,800 (10,598)	444183							√	√
3,000 (11,355)	444184							√	√

Flange Adapters

Johnson Controls Figure 71 Flange Adapters are available to adapt the grooved fittings supplied with SKUM pre-piped bladder tanks to flanged piping for field installation. The sizes listed below have a maximum pressure rating of 300 psi (20.7 bar). The flange adapter body is ductile iron and utilizes a Grade "E" EPDM gasket. Finished with Red (RAL 3000) non-lead paint.

Adapter Size		Recommended Flange Mating Bolts				
Grooved in. (mm)	ANSI Flange (DIN)	Size Dia x L in.	Qty.	Bolt Torque Range lb-ft (N-m)	Approx. Weight lb (kg)	Ordering Part Number
2 (50)	2 (DN50)	5/8 x 3	4	110 – 140 (149 – 190)	3.0 (1.4)	7120TS
2 1/2 (65)	2 1/2 (DN65)	5/8 x 3	4	110 – 140 (149 – 190)	5.0 (2.3)	7125TS
3 (80)	3 (DN80)	5/8 x 3	4	110 – 140 (149 – 190)	5.6 (2.5)	7130TS
4 (100)	4 (DN100)	3/4 x 3 1/2	8	220 – 250 (298 – 339)	7.0 (3.2)	7140TS
6 (150)	6 (DN150)	3/4 x 3 1/2	8	220 – 250 (298 – 339)	10.0 (4.5)	7160TS
8 (200)	8 (DN200)	3/4 x 3 1/2	8	220 – 250 (298 – 339)	16.6 (7.5)	7180TS

Touch Up Paint

Touch up paint for Red (RAL 3001) equipment is available in a convenient 7 ounce spray can. Touch up paint for other colors is not available in spray cans. Contact Johnson Controls for touch up paint in other colors.

Red (RAL 3001) Touch Up Paint – Part Number: 405581.

Custom Engineering

SKUM pre-piped bladder tanks can be customized to accommodate a variety of special requirements, including but not limited to ladders, platforms, alternate materials of construction, higher design pressures, space constraints, larger capacities, and seismic rated tanks.

Contact Johnson Controls or a SKUM Regional Sales Manager for additional information or to obtain a quote. **Note:** UL Listed tanks are limited to maximum capacities of 4,000 gal (15,142 L) for horizontal tanks with maximum working pressures of 175 psi to 250 psi (12.1 bar to 17.2 bar). FM Approved tanks are limited to maximum capacities of 3,000 gal (11,355 L).

Note: The converted values provided in this document are for nominal reference only and do not reflect an actual measurement.

SKUM and the product names listed in this material are marks and/or registered marks. Unauthorized use is strictly prohibited.